

Interface Force Measurements Ltd
Unit 19 Wellington Business Park
Dukes Ride, Crowthorne
Berkshire, U.K. RG45 6LS

interface
ADVANCED FORCE MEASUREMENT

Low Cost, Portable Force Gauge and Load Cell Test Systems

If you have a requirement for low cost, on site calibration or testing of your load cells and force gauges but can't justify the high cost of an electric, hydraulic or air powered test machine, then we have the solution.

The IFMLD-25XLT, rated to 25kNs is a portable force test frame used to mechanically test or calibrate load cells and gauges without requiring power from an external source.

The IFMLD-25XLTs key features are:

- Simple, fast set up
- No tools required for installation or adjustment
- Portable and light weight
- 25KN load capacity in tension and compression
- Accurate , repeatable , stable forces
- Easily adapted to accept different load cells and force gauges

Kit Options

Rated to 25kN, this mechanical loading device can be supplied with universal adaptors so you can add your own load cell and indicator. Or take one of three different kits available at very special prices, with a choice of Interface S-beam, Low Profile or Gold Standard, calibration grade load cells with matching digital indicator and cables to meet your requirements.

All kits are an "out of the box" solution with complete system kits supplied with load cell and digital indicator set up to work together. All load cells are supplied with a factory NIST or ASTM traceable calibration certificate as appropriate.



interface
www.interface.uk.com

DS IFMLD-25kN 02 handout A5 2010_1004A

Phone +44 (0)1344 776666

Fax +44 (0)1344 774765

E-mail

info@interface.uk.com

Interface Force Measurements Ltd
Unit 19 Wellington Business Park
Dukes Ride, Crowthorne
Berkshire, U.K. RG45 6LS

interface
ADVANCED FORCE MEASUREMENT

Alternative or additional calibrations are available at extra cost for both load cells and indicators, please ask for details. Test frame, and complete kits are supplied with a one, year return to base warranty to cover against defects in materials or workmanship.

Dimensions

The IFMLD-25XLT is designed to be as portable as possible while offering the highest possible accuracy. Therefore weight and dimensions have been kept to a minimum

The IFMLD-25XLT is offered with a choice of Interface SSM-AJ-25KN S-beam load cell, 1210-AF-25KN-B low profile load cell with base or the Interface's Gold Standard 1610-AF-22KN calibration grade load cell. If you require load cells data sheets, please e-mail us at info@interface.uk.com or visit our web-site www.interface.uk.com.

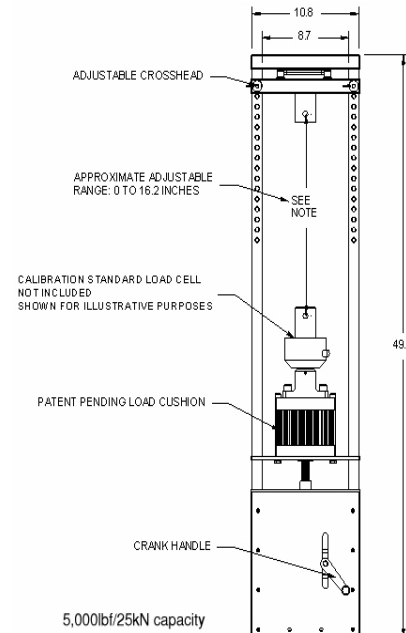

interface
www.interface.uk.com

DS IFMLD-25kN 02 handout A5 2010_1004A

Phone +44 (0)1344 776666

Fax +44 (0)1344 774765

E-mail

info@interface.uk.com