

Model 5300 Series Reaction Torque Cells



Why INTERFACE 5300 Series
Reaction Torque Transducers
are the best in class:

- High Torsional Stiffness
- Extraneous Load Resistance
- Compact Size

STYLES	CAPACITIES	
	(lb-in)	(oz-in)
5305 Mini Shaft		10,25,50,100,160
5310 Shaft	20K, 50K, 100K, 200K, 300K	
5320 Flange	200K, 300K	
5330 Hollow Flanged	60, 120, 240, 600, 1200, 3000, 6000, 10K, 20K, 50K, 100K	
5340 Flat	50, 100, 200, 500	

SPECIFICATIONS

ACCURACY – (MAX ERROR)

Nonlinearity-% FS±0.1
 Hysteresis-% FS±0.1
 (5330 & 5305-10±0.05)
 Nonrepeatability-%±0.05

TEMPERATURE

Compensated Range-°F±75 to ±175
 Compensated Range-°C+24 to +80
 Operating Range-°F-65 to +225
 Operating Range-°C-54 to +107
 Effect on Output-%/F-MAX±0.002
 Effect on Zero-% RO/F-MAX±0.002

ELECTRICAL

Rated Output-mV/V (Nominal)1.5
 (5330 & 5305-101.0)
 Bridge Resistance-Ohm (Nominal)350
 (5330-3K thru 100K700)
 Excitation Voltage-MAX10 VDC
 (53058)

MECHANICAL

CalibrationCW & CCW
 Safe Overload-% CAP200

DIMENSIONS

See Drawing	MODEL 5305 MINI SHAFT STYLE
	CAPACITY 10, 25, 50, 100, 160
	oz-in
①	1.249 +0/-0.001
②	1.50
③	1.50
④	0.249 +0/-0.001
⑤	2 FLATS @ 90°
⑥	3.188
⑦	1.00
⑧	6-32 x 0.25 deep, 4 places
⑨	1.00

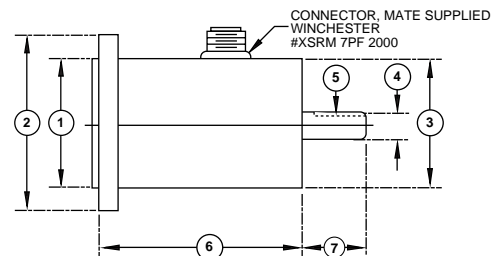
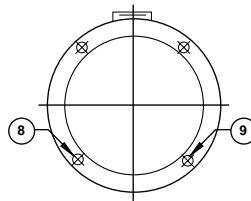

Model 5305

DIMENSIONS

See Drawing	MODEL 5310 SHAFT STYLE	
	CAPACITY	
	20K, 50K, 100K	200K, 300K
	lb-in	lb-in
①	5.125	7.125
②	8.75	7.75
③	5.50	7.50
④	3.000 +0/-0.001	4.50
⑤	0.75 square	1.00 square
⑥	19.0	22.0

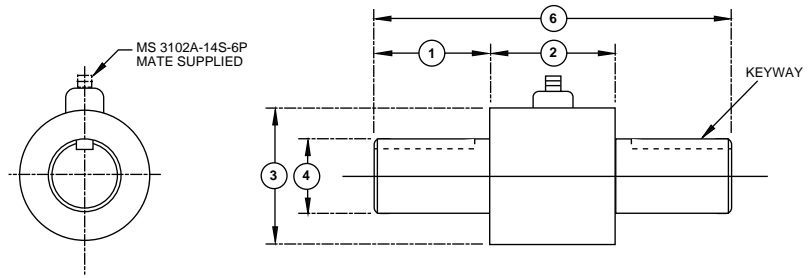

Model 5310

DIMENSIONS

See Drawing	MODEL 5320 FLANGE STYLE	
	CAPACITY	
	200K, 300K	
	lb-in	
①	0.75	
②	10.375	
③	12.0	
④	13.0	
⑤	0.630 thru 16 places	

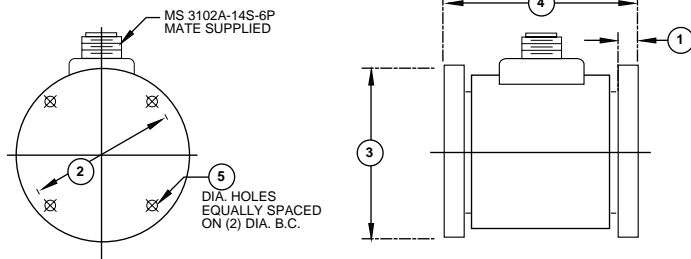

Model 5320

DIMENSIONS

See Drawing	MODEL 5330 HOLLOW FLANGE TYPE				
	CAPACITY				
	60, 120, 240	600, 1200	3K, 6K	10K, 20K	50K, 100K
	lb-in	lb-in	lb-in	lb-in	lb-in
①	0.3125	0.3125	0.3125	0.625	0.625
②	2	2.5	3.375	4.375	7.00
③	2.5	3.25	4	5	8.5
④	2.125	2.125	2.125	3.5	3.5
⑤	0.203 thru 2 places	0.39 thru 2 places	0.406 thru 4 places	3/8-24 UNF 6 places	0.63 thru 8 places
⑥	.875 thru	1.375 thru	2.375 thru	3.375 thru	3.375 thru

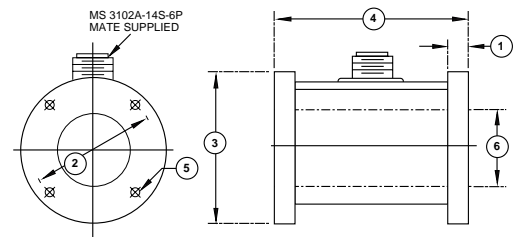

Model 5330

DIMENSIONS

See Drawing	MODEL 5340 FLAT TYPE	
	CAPACITY	
	50, 100, 200, 500	
	lb-in	
①	.375	
②	2.500	
③	4.50	
④	1.34	
⑤	3/8-24 UNF-2B x 0.312 deep, 4 places	
⑥	1.000 +0.001/-0 thru	
⑦	10-32 UNF-2B x 0.50 deep, 4 places	
⑧	1.380	
⑨	3.50	

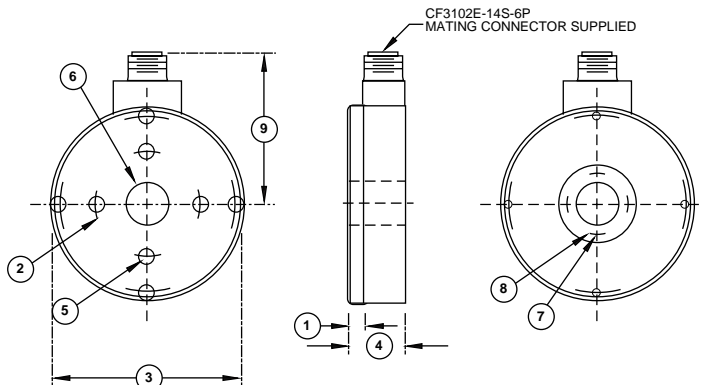

Model 5340